

# Electric Vehicle DC-DC Installation and Wiring Guide

Belktronix

Initial Release 11/12/06

Revised 10/20/10

Rev 1.8

# Document Revision History

- 1.0 Initial release
- 1.1 Revised 4” fan to 80mm fan, changed text to match labels, fan info & wiring text
- 1.2 Added detailed mounting information and instructions for the DC-DC
- 1.3 Added more clarity for wiring sizes and precharge schematic.
- 1.4 Added pictorial view of DC-DC mounting bracket and restructured detailed install
- 1.5 Added pre-charge jumper illustrations prior to fuse install
- 1.6 Defined Pre/Post contactor connections, softstart options & connection
- 1.7 Clarified connection points for remote enable
- 1.8 Renamed OUT for +DCOUT, -DCOUT

# System Wiring

**DANGER: Working with HIGH VOLTAGE Systems can be FATAL.**

**Follow Guidelines. Maximize Caution. Avoid Distractions.**

- The following slides show Pre and Post contactor connections based on option selected (Auto-Start, Soft-Start and/or Remote Enable)
- Each wiring task is illustrated to make it easy to follow, point to point.
- Route low signal wiring away from high current wires.
- A 3 Traction Battery string is illustrated in the diagrams, your system will have more. For custom voltages, contact factory for voltage limits.
- See page 7 regarding pre-charging during the installation process.
- The external 80mm cooling fan is supplied by the user. Use fan to match battery voltage, supply on/off control. Avoid low CFM fans (super quiet type).
- Enable DC-DC converter after DCIN is powered (Remote Enable option).
- For maintenance with Remote Enable option (no Soft-Start) use the Pre-Charge jumper prior to reconnecting DCIN (See Page 7).

# Hardware Information

**DANGER – USE CAUTION WORKING WITH HIGH VOLTAGE AND CURRENT!**

Extra hands may be needed for this installation, if mounting holes are out of reach.

Use safe wiring practices and recommended fuse ratings.

## **Items included with DC-DC:**

- (2) ¼-20 Bolts
- (2) ¼-20 Serrated shoulder nuts
- (1) 8.7” Mounting Bracket, fin mounted
- (2-4) 0.250 Female insulated Fast-on terminals

## **Items Required:**

10Ga Wire

18Ga Wire

Fuse Holders

(2) ¼ Ring Lugs, 12-10Ga.

Fuses (1) 10A 250V. (1) 60A Automotive

Proper crimping tool required for Crimp lugs and Fast-on Terminals. Available at automotive stores.

# Detailed Mechanical Installation

- The 8.7" rectangular aluminum mounting bracket slides over the centermost fin of the DC-DC with the 2 fan mounting holes facing up. The ends are ¼ through holes for mounting the threaded rods to the mounting surface.
- Locate a flat area in engine compartment which is away from direct exposure to outside elements (i.e. front grill).
- Use aluminum mounting bracket as a template and mark holes to be drilled on vehicle chassis.
- Align DC-DC with fins facing you vertically if no external fan is used. Horizontal OK with fan.
- Drill through with ¼ drill (blind holes require proper drill/tap to use with ¼-20 thread).
- Run bolts through mounting holes and secure on backside with serrated shoulder nuts.
- Secure rubber mat to mounting surface with tape, place DC-DC onto rubber mat and hold in place.
- Insert topside bracket (bracket slot facing heatsink) onto centermost heatsink fin, sliding over threaded rods.
- Tighten bolts onto bracket. Be sure DC-DC is secure. External Fan is needed if high output power or high ambient temperatures are required.
- Wire up battery ground paths to DC-DC first. Hold ring lugs securely while tightening to DC-DC high current posts.
- Use correct connection method of wiring Pre or Post contactor for DCIN wiring.
- Ready-up positive wires to DC-DC but do not install yet. Cover exposed terminals.
- For POS output post, Pre-charge with resistor lead for 30 seconds, then connect ring terminal and secure tight.
- Wire up remote enable to switched 12V (if equipped). You can use this to power the fan as well.
- Unit is ready to run when power is at DCIN terminals on the DC-DC and remote switch is enabled (if equipped).
- Softstart option will automatically enable the DC-DC internally after approximately 20 seconds.

# Mounting Diagrams

(Fan shown optional)

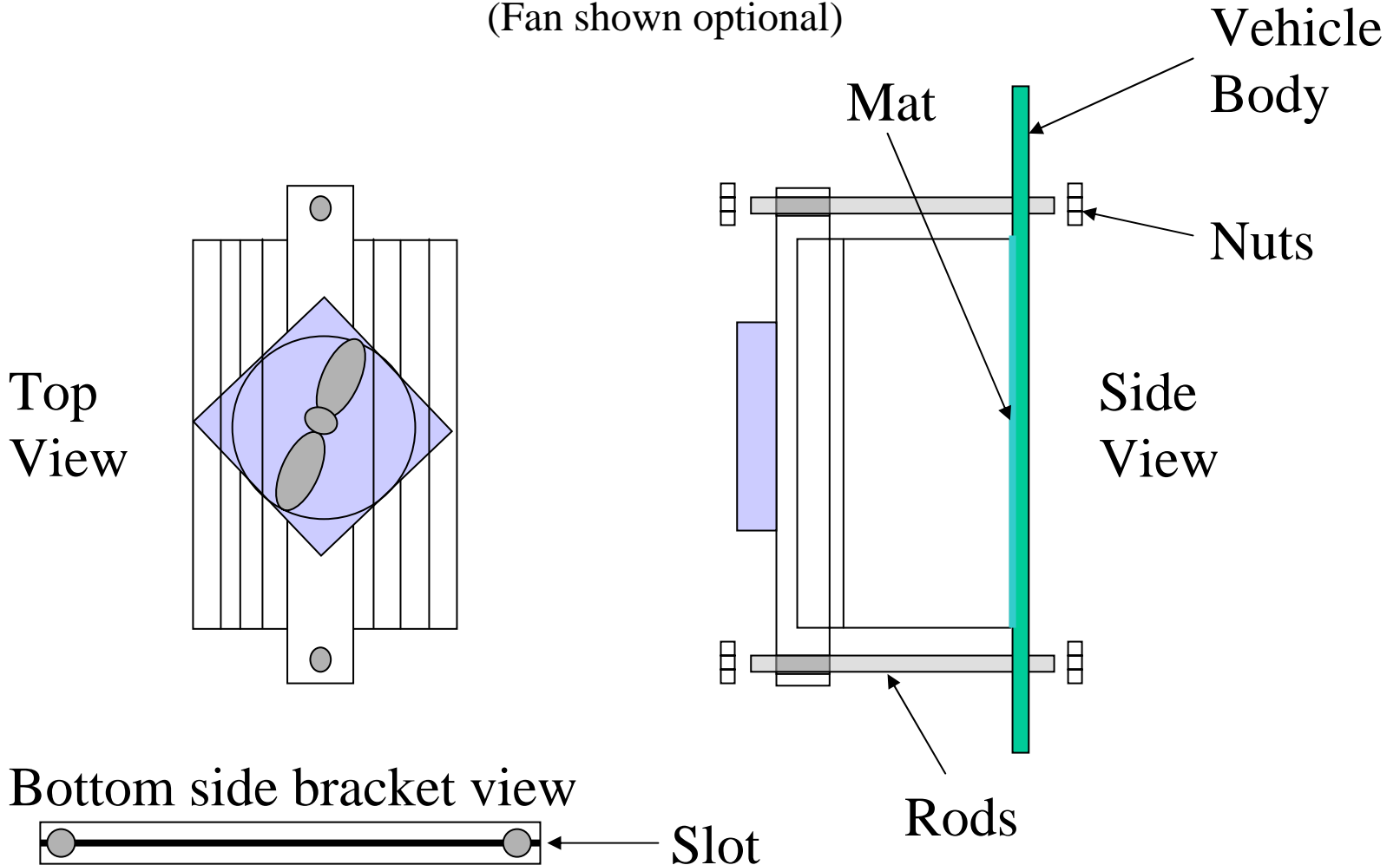

# Pre-Charging Internal Capacitors

Not Required on DCIN side with Auto-Start or Soft-Start option!

PRECHARGE FIRST, then install fuses!

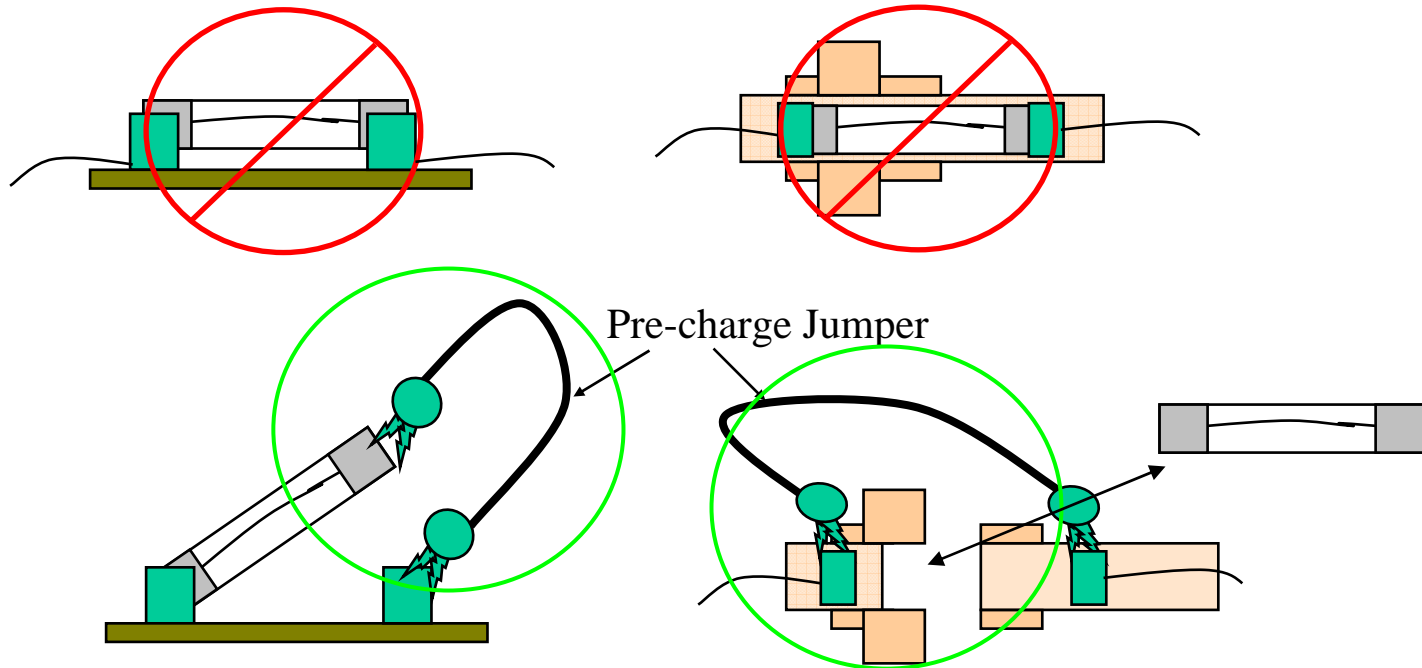

# DC-DC Power & Signal Wiring

## Auto-Start Option

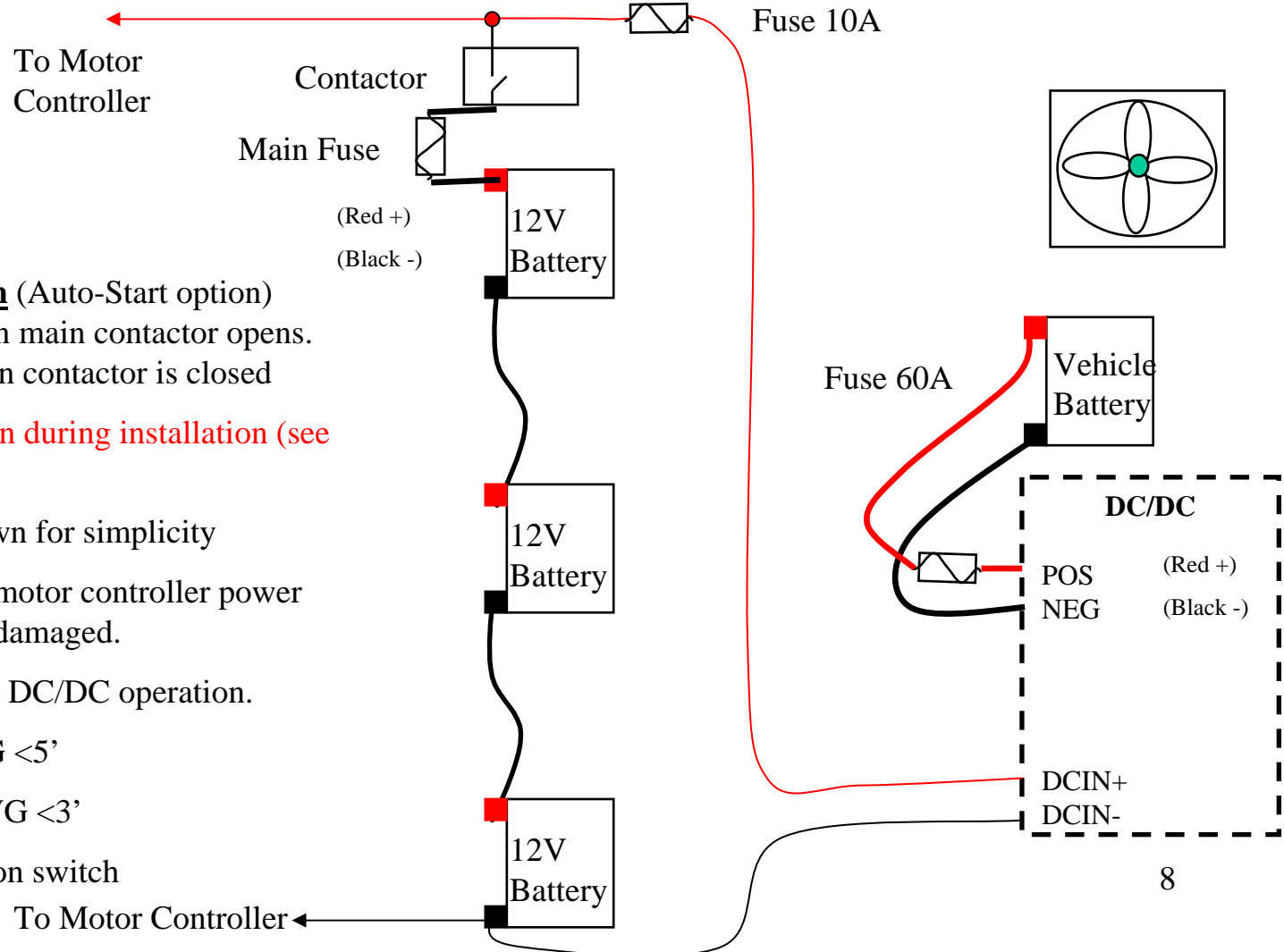

### Post Contactor Connection (Auto-Start option)

The DC-DC is isolated when main contactor opens. Automatically starts up when contactor is closed

Pre-charge output connection during installation (see page 7)

Traction Pack String, 3 shown for simplicity

Do not connect DCIN with motor controller power connections or unit may be damaged.

Vehicle Battery required for DC/DC operation.

DC Input wire size 18 AWG <5'

DC Output wire size 10 AWG <3'

Use 12V fan wired to Ignition switch

To Motor Controller

# DC-DC Power & Signal Wiring

## Soft-Start option & Remote Enable

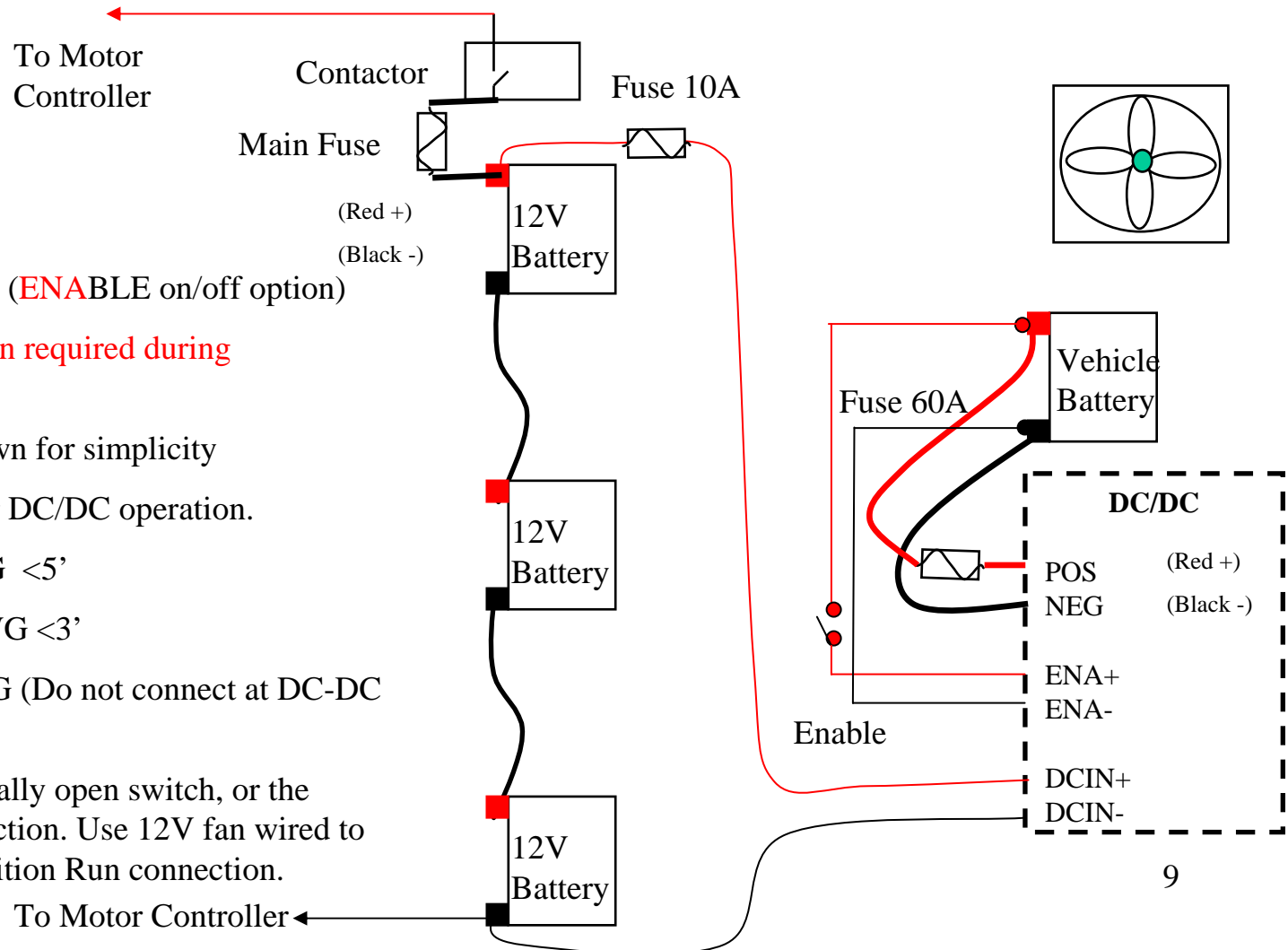

**Pre-Contactor Connection** (ENABLE on/off option)

Pre-charge output connection required during installation (see page 7)

Traction Pack String, 3 shown for simplicity

Vehicle Battery required for DC/DC operation.

DC Input wire size 18 AWG <5'

DC Output wire size 10 AWG <3'

ENABLE wire size 22 AWG (Do not connect at DC-DC output).

Enable can be a SPST normally open switch, or the Vehicle Ignition Run connection. Use 12V fan wired to SPST switch or Vehicle Ignition Run connection.

# DC-DC Power & Signal Wiring

## Remote Enable Only (No Soft-Start option)

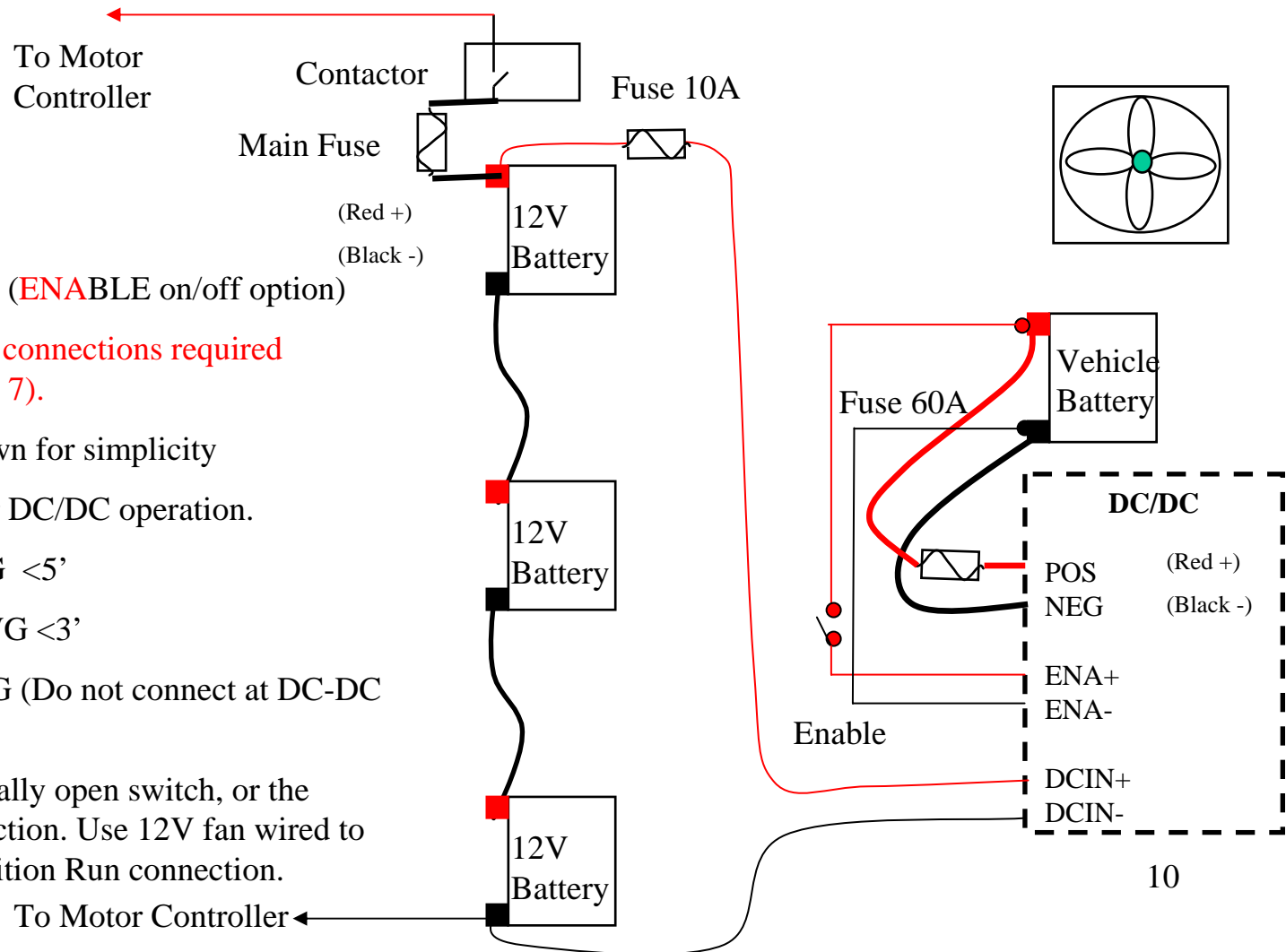

**Pre-Contactor Connection** (ENABLE on/off option)

Pre-charge input and output connections required during installation (see page 7).

Traction Pack String, 3 shown for simplicity

Vehicle Battery required for DC/DC operation.

DC Input wire size 18 AWG <5'

DC Output wire size 10 AWG <3'

ENABLE wire size 22 AWG (Do not connect at DC-DC output).

Enable can be a SPST normally open switch, or the Vehicle Ignition Run connection. Use 12V fan wired to SPST switch or Vehicle Ignition Run connection.